

A CALORIMETRICAL APPARATUS FOR STRETCHING EXPERIMENTS WITH  
FROG MUSCLES

M. Schlipf and G.W.H. Höhne

Sektion für Kalorimetrie der Universität Ulm, Postfach 4066  
D 7900 Ulm (FRG)

Abstract:

A commercial heat-flow calorimeter has been improved to measure the heat of deformation of frogmuscles in Ringer-solution. The calorimeter arrangement allows the measurement of work and heat of about 50  $\mu$ J in 20 ml liquid. Preliminary results on ilio fibularis of rana temporaria are reported.

Introduction:

From the early 30's until the 50's stretching measurements on the semitendinosus and sartorius muscle of various types of frog were carried out (e. g. Feng 1932, A.V. Hill 1952). A Hill-Downing thermopile was universally used for these measurements. However it is not possible to make good long term measurements with this device and it is difficult to determine the exact amount of heat involved. In a recent discussion of the inter-relationship between heat and work in muscles (Curtin, Woledge 1978) the necessity of knowing the absolute amounts of heat in small stretching intervals near the resting length was pointed out. In order to be able to do this we modified a commercial heat-flow calorimeter\* to carry

\*Typ BCP ARION Grenoble, France

out measurements on muscles of *rana temporaria* and *esculenta* in Ringer solution.

The liquid surrounding is necessary because it is often convenient to be able to block some biochemical functions of a muscle by varying the solution. This imposed a further difficult requirement on our calorimeter. The amounts of heat expected to be produced were of the order of 10 to 100  $\mu$ J for stretching intervals between the resting length ( $l_0 = 2,0 \mu$ m sarkomer length) and 1,2 - 1,6 of  $l_0$ . The heat of vaporization of only  $2 \cdot 10^{-8}$  g of water is of the same quantity, therefore every evaporation during the measurements gives very large fluctuations of the baseline and must be avoided.

#### Experimental:

The heat-flux calorimeter (fig. 1) which will be described here is of the isoperibolal type, and the measuring system consists of batteries of Peltier elements which have a low thermal resistance and a high sensitivity of 50  $\mu$ V/mW.

The time constant of the system is 330 s. The dimensions of the measuring cell were, height: 77 mm, diameter: 19 mm, and contains about 20 ml solution.

Normally the temperature was regulated with a PID-controlled heater which surrounded the apparatus. This system allowed quantities of heat down to  $20 \cdot 10^{-3}$  J to be measured. For lower solutions the oscillations of the PID-controller were visible on the recorder and made interpretation of the heat-peaks difficult or impossible. Therefore the PID-controller was replaced by a DC source with a voltage stability of  $10^{-5}$ , and the whole measuring system was placed in a thermostat which was regulated to  $\pm 0,05^\circ$  K.

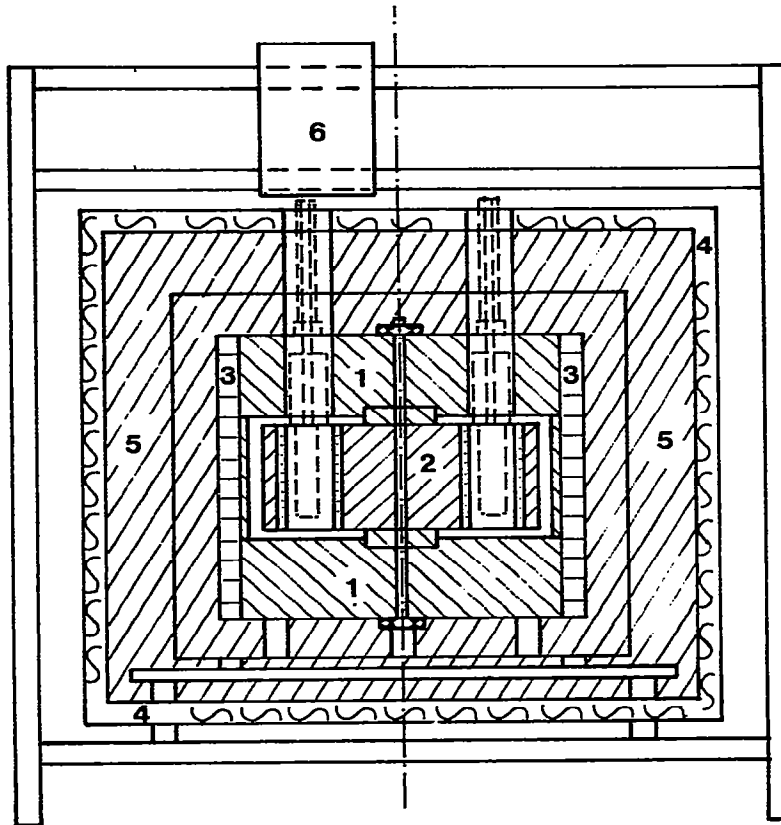

fig. 1: Calorimeter arrangement, 1 isothermal aluminium-block, 2 holder for Peltier-elements and sample-cell, 3 heater, 4 thermostat, 5 mineral-wool, 6 force- and distance-measuring-heads.

The space between the thermostat and the measuring system was filled with mineral-wool to smooth the heat oscillations from the thermostat, and to prevent convection.

The whole system needs about 3 days to reach a thermally steady-state. The background noise on a typical measuring curve was about  $5 \cdot 10^{-9}$  V or  $0,1 \mu\text{W}$ . (see fig. 3)

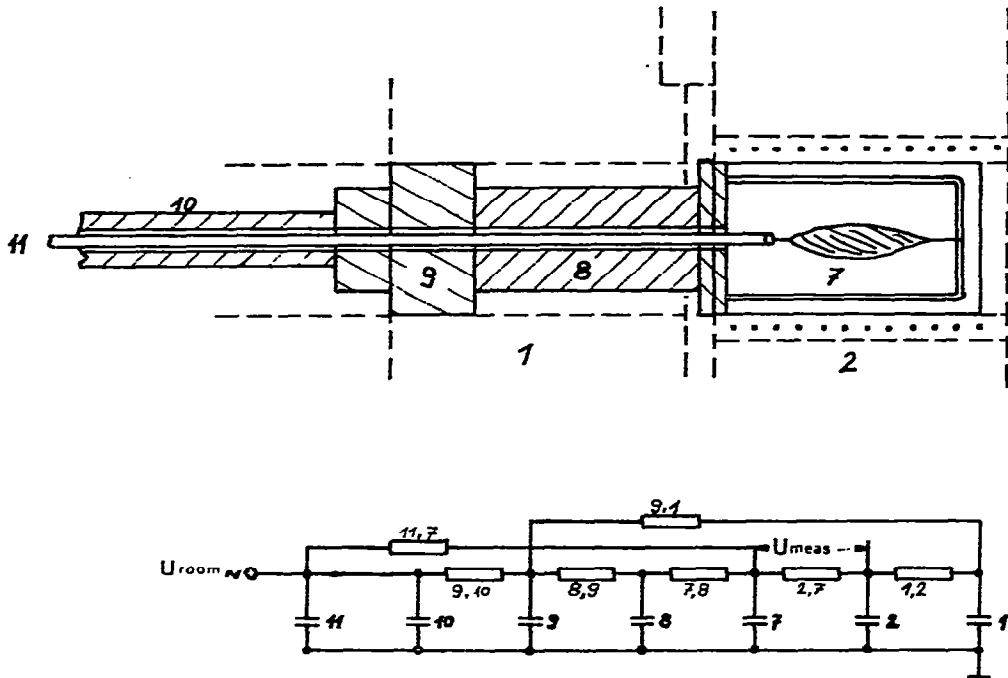

fig. 2: The sample-cell (turned  $90^{\circ}$ ) and the equivalent electrical network. 1 isothermal aluminium-block, 2 holder for sample cell with Peltier-battery (see fig. 1), 7 measuring volume (sample and solution), 8, 10 PVC-stake, 9 aluminium-cylinder, 11 traction stick of Duran-glass.

In order to be able to carry out stretching experiments in a calorimeter it is necessary to couple the muscle mechanically to a force-transducer and a distance-transducer, which are situated outside the thermostated region. However this force transferring mechanical coupling also represents a heat conducting pathway between the room and the measuring volume although the traction-stick is build of a 1 to 0,1 mm thick Duran-glass filament ( $\lambda = 10^{-2}$  W/K.cm, heat flow =  $2 \cdot 10^{-6}$  W/K).

Room-temperature can be regulated best to  $\pm 1^{\circ}\text{K}$ .

For to avoid heat-flow-oscillations into the measuring system new cells were constructed. The construction of these is shown in fig. 2, together with the equivalent electrical network. The heat-flow signal is measured between (7) and (2). Peltier-batteries (with holder (2)) were preserved from oscillations of the room-temperature by a thermal bypass: A cylindrical part of aluminium (9) is directly coupled to the upper thermostat block (1) of the calorimeter. Between this point and the measuring volume (7), there is a part of PVC (8) which has a great thermal resistance ( $\lambda = 4 \cdot 10^{-3} \text{ W/K.cm}$ ). The junction between part (9) through the thermostat to the room, is a cylindrical part of PVC (10) with a smaller diameter than part (8). The heat capacity of (1) is very large and the thermal resistance between (9) and (1) very low, while the thermal resistances of the glass stick ( $R_{11,7}$ ) and the PVC-stake (8) ( $R_{8,9}$  and  $R_{7,8}$ ) are large. Therefore the variations of the room-temperature don't reach the measuring volume (7).

#### Calibration of the calorimeter.

To determine the absolute relationship between heat and recorder deflection we calibrated the calorimeter with a metal-film-resistance, through which a known amount of electricity was passed. In 20 ml solution it is possible to detect amounts of heat of 20  $\mu\text{J}$  with an accuracy of  $\pm 15 \%$  (see fig. 3)

In stretching experiments every solid produces heat effects during force-changing, therefore the effect of tension on the muscle-holder, the traction-stick and other parts of the apparatus must be well known, for to separate from the heat changes in

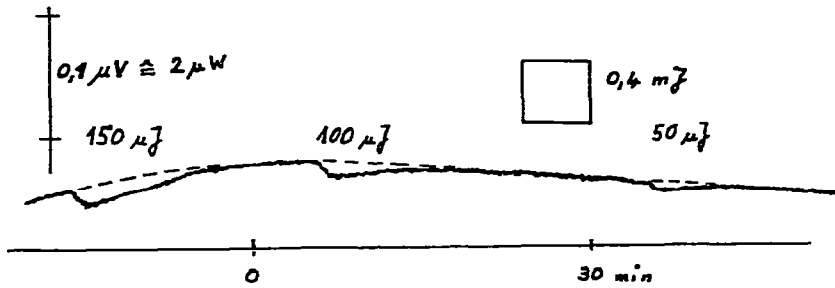

fig. 3: Baseline with calibration-peaks

muscle. To measure this a stainless-steel-spring with a force-constant similar to muscle (and with known small thermal effect during stretching) was placed inside the measuring cell and tied just like muscle. The so measured heat-production of the apparatus is subtracted from the heat of muscle measurements to get the stretching-heat of muscle alone.

Preliminary results of iliofibularis of rana temporaria.

The muscle investigated in our experiments was the iliofibularis because of its easy preparation and its homogenous structure of fibres. The muscles were stretched in Adrian-Ringer solution. Fig. 4 shows the results of two typical measurements, one of a winterfrog and one of a summerfrog. There is a difference in the heatflow-curve: The winterfrog-muscle produced an exothermic heat for stretching and an endothermic for releasing, while the summerfrog-muscle showed a transposition of the baseline indicating an increase of metabolism during stretching. For to separate the heat of deformation from the change of the heat of metabolism we desmeared (Höhne, 1978) the measured heat-flow-curve and than we subtracted the heat flow change of metabolism

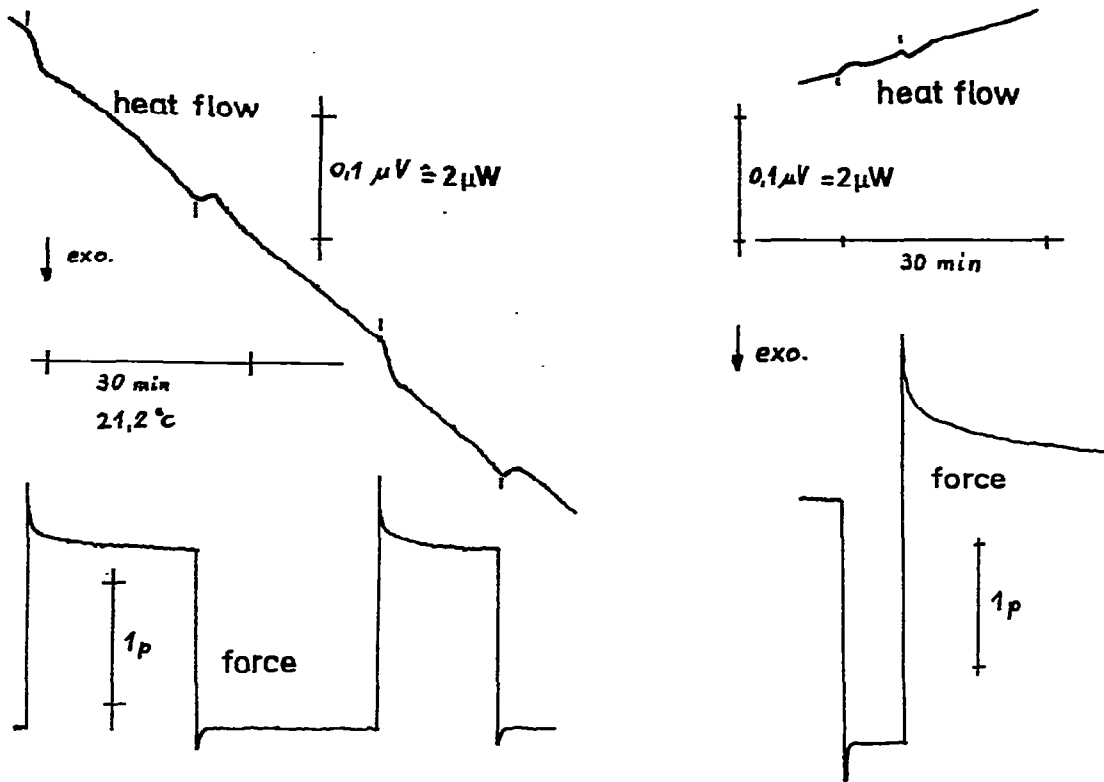

fig. 4: Two typical measurements of summerfrog (left) and winterfrog (right).

(expected to be rectangular). After correction of the heat of deformation of the apparatus, we got the heat of deformation of the muscle. Fig. 5 shows the results of force, work and heat of deformation of two muscles of a summerfrog at two temperatures. The heat is exothermic for stretching and seems to decrease for larger than 25% deformation to zero at about 30%. Other muscles showed similar results.

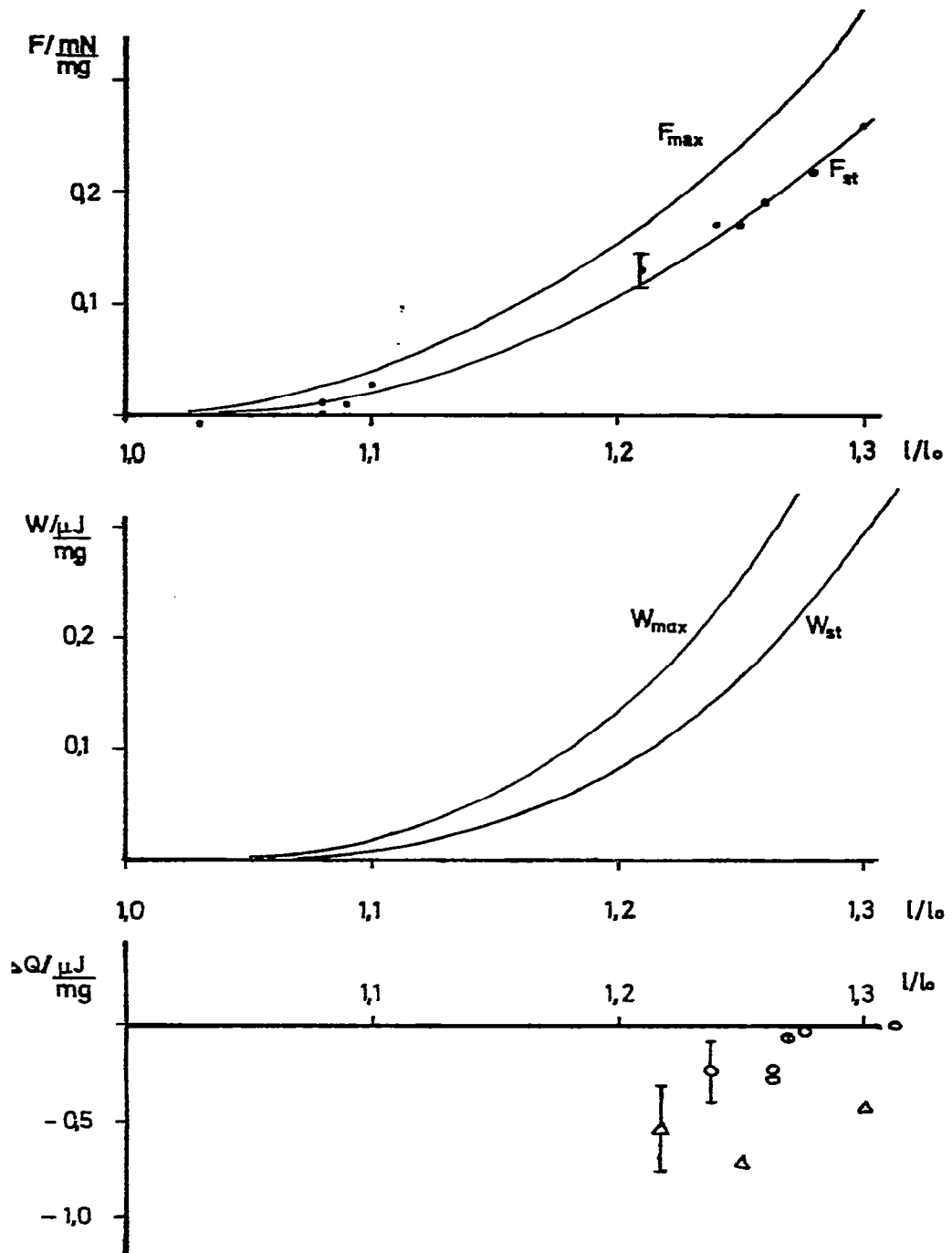

fig. 5: Force ( $F$ ), work ( $W$ ) and heat change ( $Q$ ) of two iliofibularis at  $21,2^{\circ}\text{C}$  (  $\circ$  ) and  $16,6^{\circ}\text{C}$  (  $\Delta$  ) ( $F_{\text{st}}$  is the curve, for force is in a steady-state)



### References

- N.A. Curtin, R.C. Woledge, *Physiol. Rev.* 58 (1978) 690 ff  
T.P. Feng, *J. Physiol.* 74 (1932) 441 ff and 455 ff  
A.V. Hill, *Proc. Roy. Soc. B* 139 (1952) 464 ff  
G.W.H. Höhne, *Thermochim. Acta*, 22 (1978) 347-362

### Acknowledgement

The authors wish to thank the Deutsche Forschungsgemeinschaft for supporting this work.